

New Arc Welding Robot

FANUC Robot ARC Mate 0iB



Features

The FANUC ARC Mate 0iB robot is an extremely lightweight and compact low cost robot, specifically designed for arc welding applications. The ARC Mate 0iB will work for a wide variety of arc welding applications, including smaller parts that are normally done with manual welding.

- The lightweight and compact arm design of the ARC Mate 0iB provides a highly reliable package that is optimized for arc welding applications that require delicate motion.
- The latest servo technology provides high-speed and accuracy of the robot motion and minimizes the interaction of the operator to increase the efficiency of the arc welding system.
- Digital communication between the latest Lincoln Arc Welding Power Supply and the ARC Mate 0iB provides superior control and performance, creating the highest quality weld.
- Various welding waveforms such as thin metal spatter-less welding and highly-controlled pulse welding can be applied to almost any application for an optimized weld.
- The R-30iB Mate controller has the latest arc welding software available, including 4D graphics for easy programming and operation.

Application system

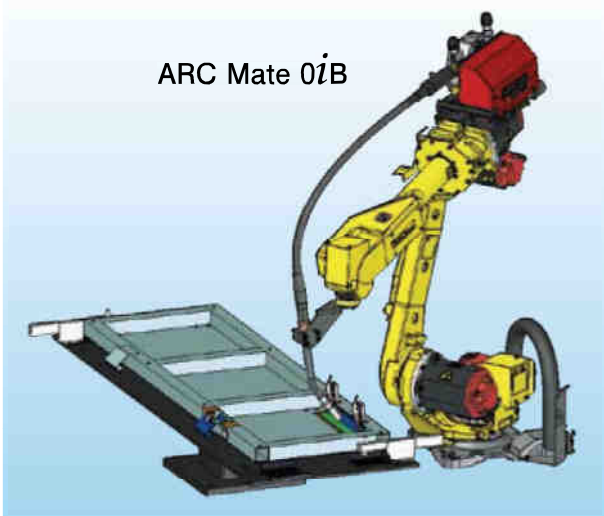

ARC Mate 0iB

Small part arc welding system with the ARC Mate 0iB

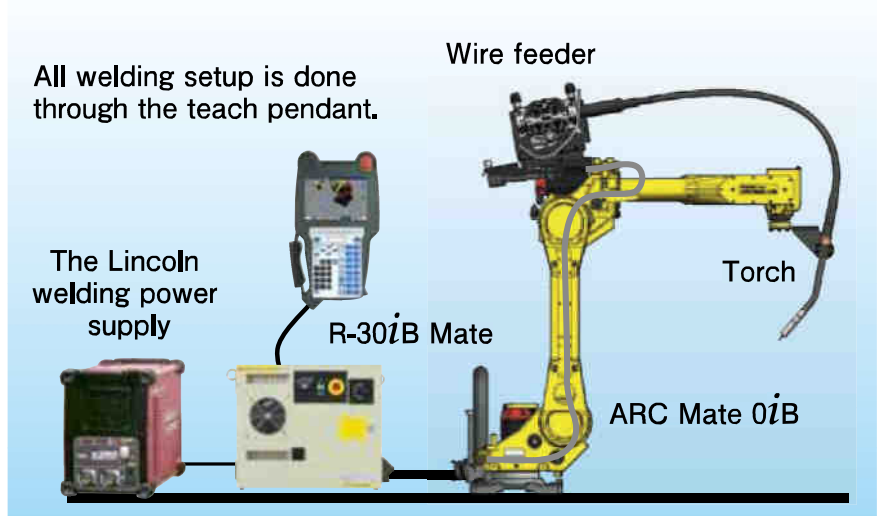

All welding setup is done through the teach pendant.

The Lincoln welding power supply

Wire feeder

R-30iB Mate

Torch

ARC Mate 0iB

Arc welding robot package with ARC Mate 0iB

FANUC Robot ARC Mate 0iB

Operating space

Standard installation (no pedestal)

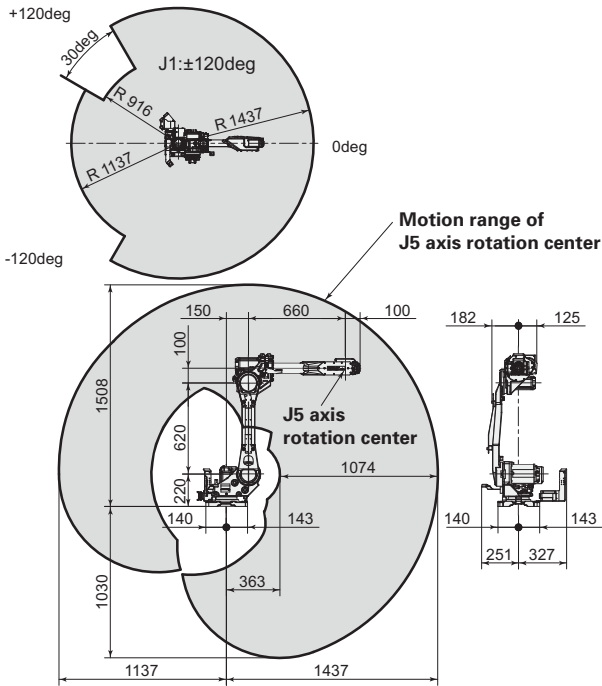

Pedestal option installation

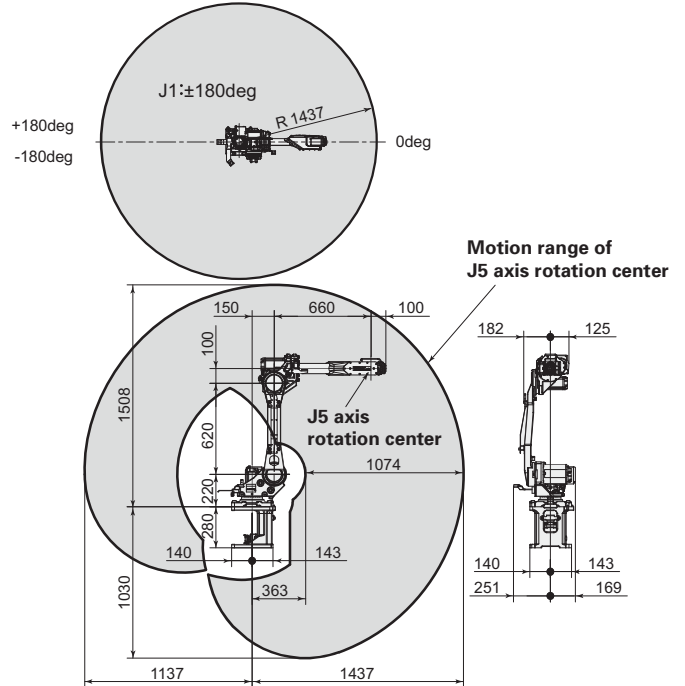

Robot Specifications

Model	ARC Mate 0iB	
Controlled axes (Note 1)	6 axes (J1, J2, J3, J4, J5, J6)	
Reach	1,437 mm	
Installation	Floor, Upside-down, Angle mount	
Motion range (Maximum speed)	J1 axis rotation	240[360]°(225°/s) 4.19[6.28] rad (3.93 rad/s) (Note 4)
	J2 axis rotation	250°(215°/s) 4.36 rad (3.75 rad/s)
	J3 axis rotation	455°(225°/s) 7.94 rad (3.93 rad/s)
	J4 axis wrist rotation	380°(425°/s) 6.63 rad (7.42 rad/s)
	J5 axis wrist swing	280°(425°/s) 4.89 rad (7.42 rad/s)
	J6 axis wrist rotation	720°(625°/s) 12.57 rad (10.91 rad/s)
Maximum load capacity at wrist	3kg	
Allowable load moment at wrist	J4 axis	8.9 N·m
	J5 axis	8.9 N·m
	J6 axis	3.0 N·m
Allowable load inertia at wrist	J4 axis	0.280 kg·m ²
	J5 axis	0.280 kg·m ²
	J6 axis	0.035 kg·m ²
Repeatability	± 0.08mm	
Repeatability	99[145]kg (Note 4)	
Installation environment	Ambient temperature : 0 ~ 45°C	
	Ambient humidity :	
	Normal 75%RH or less (No dew nor frost allowed)	
	Short term : 95%RH or less (within one month)	
	Vibration acceleration : 4.9m/s ² (0.5G) or less	

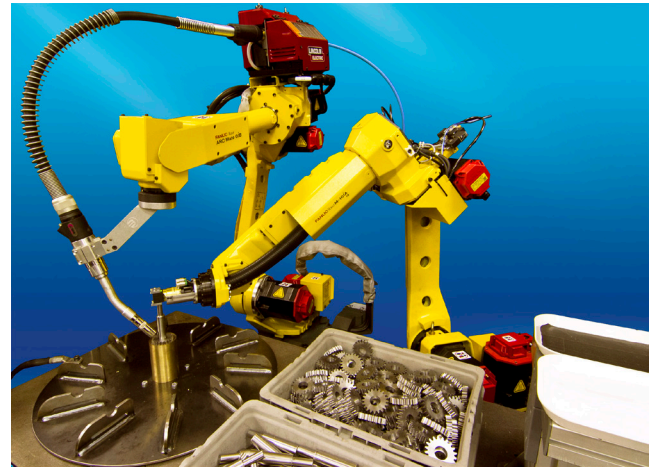

Note 1) In case of using robot combined with aux. axis, please consult with FANUC.
 Note 2) In case of short distance motion, the axis speed may not reach the maximum value stated.
 Note 3) Motion range of wrist axis may be restricted by torch to less than the values given.
 Note 4) The value in [] shown above need the pedestal option.

FANUC

FANUC AMERICA CORPORATION
 3900 WEST HAMLIN ROAD
 ROCHESTER HILLS MI 48309-3253

